

RoHS (2002/95/EC) COMPLIANT

CUSTOMER: P/N: 0401.144 REV. APPROVED BY:

| REVISIONS | | | |
|-----------|-------------|------|--------|
| REV. | DESCRIPTION | DATE | APPVD. |
| △ | | | |
| △ | | | |
| △ | | | |

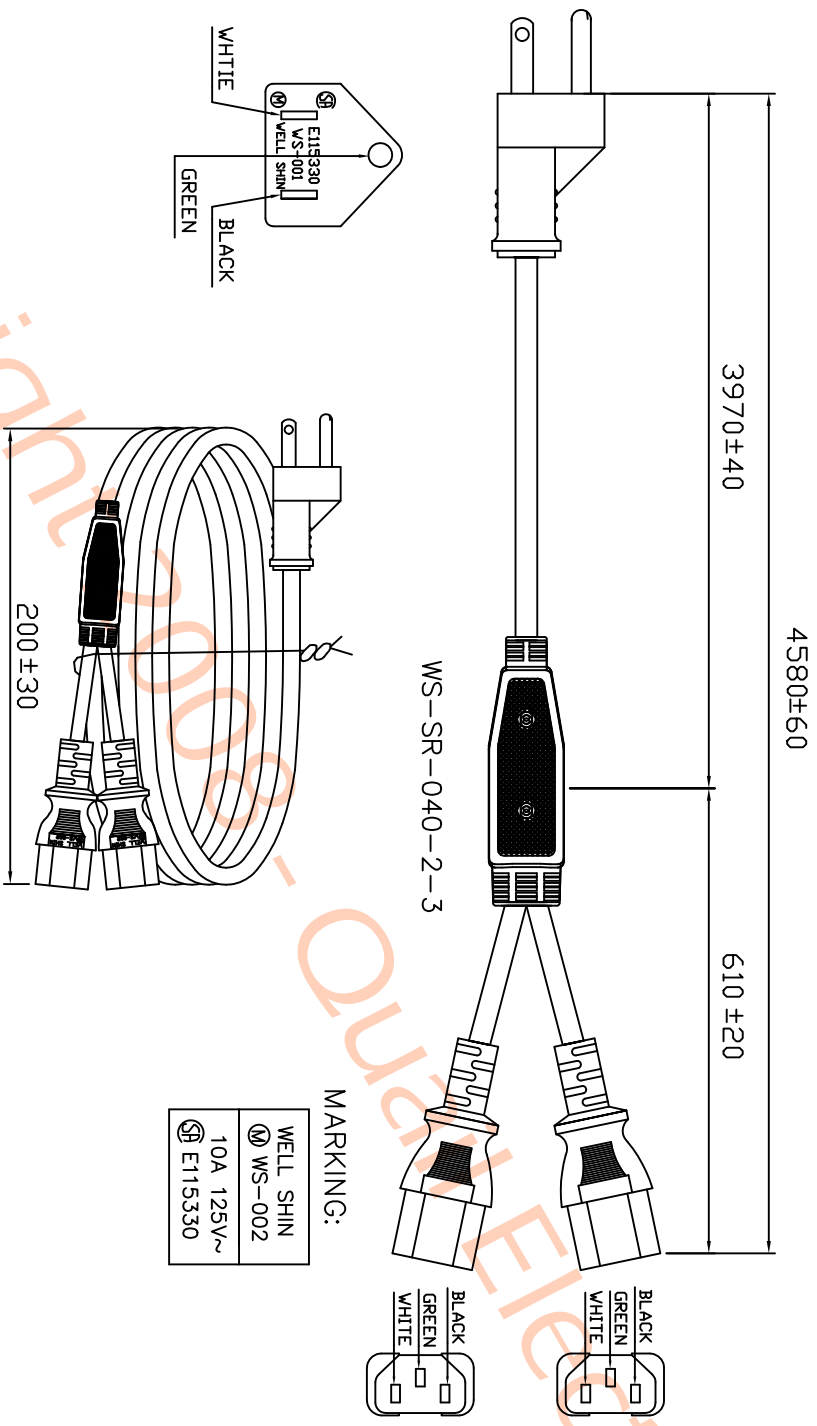

NOTES:

SPECIFICATION :

- (1) COLOR : BLACK
- (2) PLUG : WS-001(5-15P) 10 (A) 125 (V) APPROVAL : UL,C-UL
- (3) CONNECTOR: WS-002*2(IEC C13) 10 (A) 125 (V) APPROVAL : UL,C-UL
- (4) CABLE : SJTW 18AWG*3C 105°C APPROVAL : UL,C-UL

MARKING:

WELL SHIN
 WS-002
 10A 125V~
 E115330

QUAIL ELECTRONICS, INC.

http://www.quali.com

| | | | |
|--------------|-----------|-------------------|------------------|
| ENGINEER BY: | SIGNATURE | PRODUCT NO.: | DATE: 2005.05.03 |
| MANAGER BY: | | UNIT: mm | SHEET: 1 OF 1 |
| CHECKED BY: | | DWG NO: 0096-0543 | REV. A |
| DRAWN BY: | | | |

THE INFORMATION CONTAINED HEREIN IS PROPRIETARY TO QUAIL ELECTRONICS, INC. ANY USE OR DISCLOSURE OF THIS INFORMATION, EXCEPT FOR THE EXCLUSIVE BENEFIT OF QUAIL ELECTRONICS, INC. IS PROHIBITED.