

CUSTOMER: ---- P/N: 2500.180 REV. . APPROVED BY:

REVISIONS		
REV.	DESCRIPTION	DATE
△	Update cable safety regulation, Update note 1	2025/11/10

4570±50

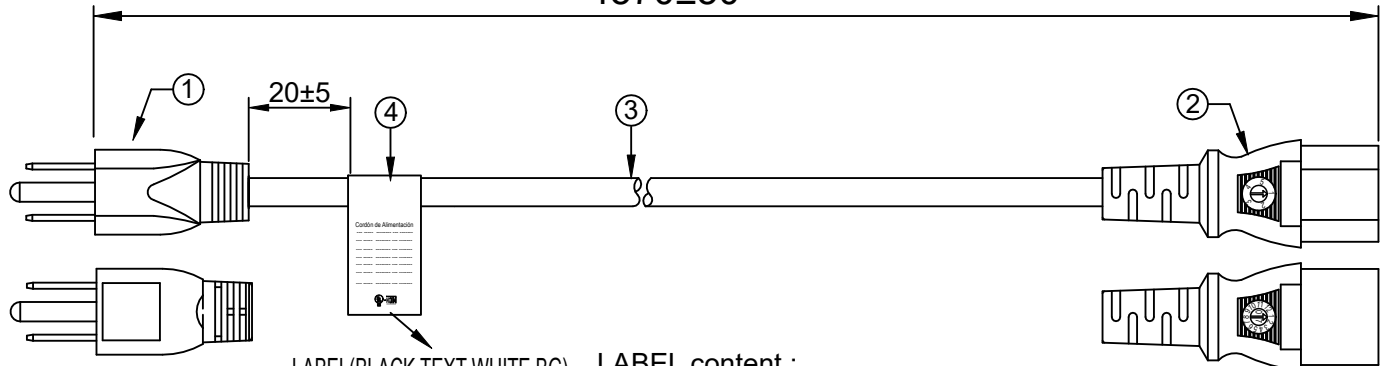

**NOTES:**

- △ 1.ZH(Zhang Hwa) factory begin from revision H
- 2.RoHS shown on the carton
- 3.inline label please refer to 0096-0001-1 REV B label on carton please refer to 0096-0001-2 REV B

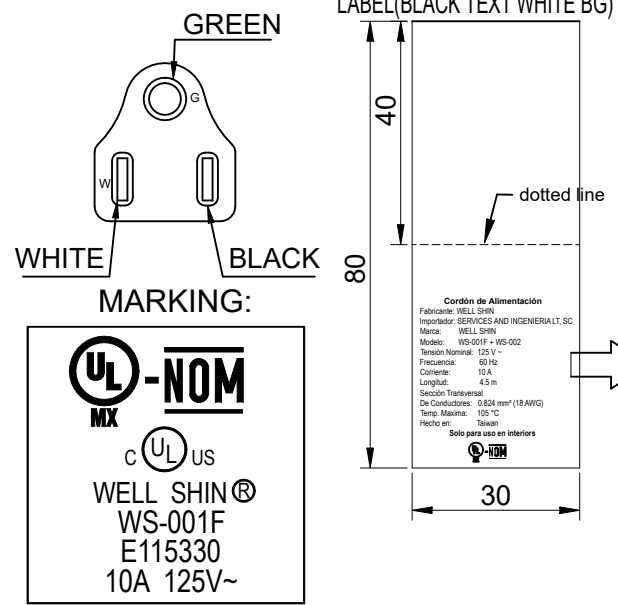

**Cordón de Alimentación**  
 Fabricante: WELL SHIN  
 Importador: SERVICES AND INGENIERIA LT, SC  
 Marca: WELL SHIN  
 Modelo: WS-001F + WS-002  
 Tensión Nominal: 125 V ~  
 Frecuencia: 60 Hz  
 Corriente: 10 A  
 Longitud: 4.5 m  
 Sección Transversal  
 De Conductores: 0.824 mm<sup>2</sup> (18 AWG)  
 Temp. Maxima: 105 °C  
 Hecho en: Taiwan  
**Solo para uso en interiores**

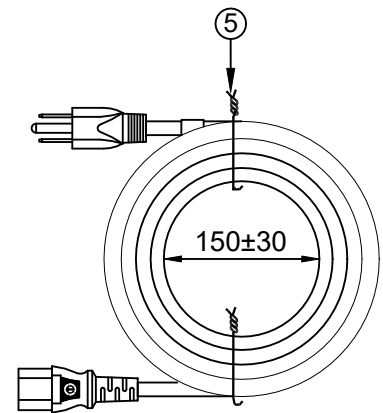
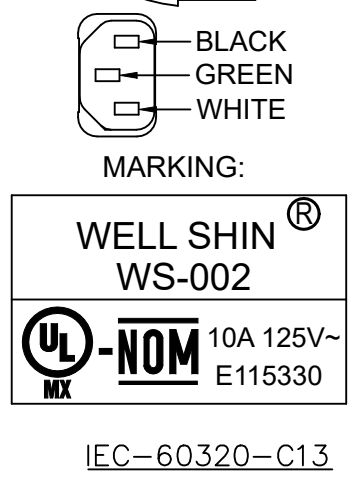

ITEM	DESCRIPTION	COLOR	QTY
⑤	Cable tie	BLACK	2
④	LABLE	---	1
③	SVT 18AWG*3C 105°C APPROVAL: UL,CUL △	BLACK	1
②	WS-002 10(A) 125(V) APPROVAL: UL,CUL,NOM	BLACK	1
①	WS-001F 10(A) 125(V) APPROVAL: UL,CUL,NOM	BLACK	1

SIGNATURE	
SAFETY ENGINEER:	
MANAGER BY:	
CHECKED BY:	
DRAWN BY:	

**QUAIL ELECTRONICS, INC.®**  
<http://www.quail.com>

PRODUCT NO.: \_\_\_\_\_ DATE: 2025/11/10

UNIT: mm SHEET: 1 OF 1 REV. \_\_\_\_\_

DWG NO: 0096-0036 O